



4K × 2K Video Processor

User Manual V2.1

⚠ Before using this LED Video processor, please read this manual carefully and preserved for reference in the future.

MAGNIMAGE

LED-780H

Statements

Without the written permission, any unit or individual could not copy, reproduction or translate the book or part of it. Also could not transmit it in any form or any way (electronic, mechanical, photocopying, record or other way) for any business and profitable purpose.

The product specifications and information mentioned in this manual is just for reference, will not give prior notice if there is any updated. Unless there is a special agreement, it is just used as guidelines. All the statements or information in this manual shall not constitute any form of guarantee

Directory

BRIEFS	1
TRADEMARK CREDIT	1
ABOUT SOFTWARE	1
FEATURES	2
EXTENDED PORT	3
SAFETY INSTRUCTIONS	5
FUNCTION INTRODUCTION	6
BRIEF	6
ABOUT THE FRONT	7
ABOUT THE BACK	8
ABOUT THE BACK	9
TECHNICAL SPECIFICATIONS.....	10
USING MENU	13
HOW TO USE THE KEYS	13
MENU:	13
WINDOWS:	14
INPUTS:	14
FUNCTION:	15
DEFAULT STATUS.....	15
MAIN MENU INTRODUCTION	16
Main Menu:	17
Image setting submenu.....	18
Output setting submenu	20

Mosaic sub menu.....	23
Switcher mode sub menu	26
PIP Setting.....	28
Image crop setting sub menu.....	29
EDID setting	30
VGA adjustment.....	31
Communication Setting.....	31
Misc Setting	32
Synchronization Lock Setting	40
Extend input port.....	41
Keypad Lock.....	41
Language/语言 Submenu	41
User Guidance.....	42

MOSAIC FUNCTION 43

SINGLE INPUT SCALED-UP MOSAIC	43
MULTIPLE INPUT SCALED-UP MOSAIC	44
2 DVI input horizontal scaled-up mosaic.....	44
NOTE OF DP.....	46

CONTROLLING SOFTWARE OPERATION INTRODUCTION..... 47

RUNNING ENVIRONMENT	47
INSTALL AND UNLOAD	47
Installing processing	48
Unload the software.....	49
OPEN THE SOFTWARE.....	50
Connection setting	51
Image setting	53
OutputSetting.....	54
Mosaic Setting.....	55
Switcher Mode.....	56

PIP	57
Image Crop	58
LOGO Setting	59
EDID Setting	60
VGA Adjustment	61
Misc Setting	62
Time & Task	65
Input Source Information	66
Synchronous Mode	67
Preset and Template	67

WARRANTY 68

THE WHOLE UNIT WARRANTY 68

THE WARRNTY PROVISIONS 68

Briefs

Thanks for your purchasing our LED Video processor. Do hope you can enjoy the experience of the product performance. The design of the LED video processor conforms to international and industry standards. But if with improper operation, there will be a personal injury and property damage. In order to avoid the dangerous, please obey the relevant instructions when you install and operate the product.

Trademark Credit

- VGA and XGA are the trademarks of IBM.
- VESA is a Video Electronics Standards Association's trademark.
- HDMI、HDMI mark and High-Definition Multimedia Interface are all from HDMI Licensing LLC.
- Even if not specified company or product trademarks, trademark has been fully recognized.

About Software

Do not change, decompile, disassemble, decrypt or reverse engineer the software installed in the product, these acts are illegal.

Features

- 4 Screens Splicing in 1 Processor: 8 DVI output ports are divided into 4 groups for horizontal splicing, vertical splicing, same size splicing, and different size splicing. A single unit up-loads 8,000,000 pixels and accepts splicing for 4 screens.
- 4 windows output: On non-splicing mode, each output is capable of displaying 4 layers with any size or position.
- Preview Switching: Preview switching between 1 image and 3 images; or between 4k and 4k
- Multiple cascade: Machines can be cascaded to realize ultra wide display.
- Built-in Input Matrix for Seamless Switching Between 8 Inputs
- EDID management & User-defined output resolution
- Rotary output: Splicing after rotary output
- DP Loop: 1 DP loop (for any input signal)
- LOGO saving & image crop
- Time and task & graphic card for testing
- Computer host control
- Save and loading preset & image freezing
- Feathering function

Extended Port

LED-780H is a basic model, on this basis, it can also expand simultaneously 2k input source【VGA、DVI、SDI optional(USB module only one way)】 or 4k input source(DP1.1 or HDMI 1.4); Or extend a IP monitoring module that can monitor the outputs (including one IP echo output and one DVI monitor output), extended models as follows:

Port		Model	Explanation
Input port	Extended one DVI port	LED-780HD	1 DVI module includes 1 DVI input and 1 DVI loop
	Extended two DVI ports	LED-780HD2	1 DVI module includes 1 DVI input and 1 DVI loop
	Extended one DVI port and one VGA port	LED-780HDV	1 DVI module includes 1 DVI input and 1 DVI loop; 1 VGA module includes 1 VGA input and 1 VGA loop
	Extended one DVI port and one SDI port	LED-780HDS	1 DVI module includes 1 DVI input and 1 DVI loop; 1 SDI module includes 1 SDI input and 1 SDI loop
	Extended one VGA port	LED-780HV	1 VGA module includes 1 VGA input and 1 VGA loop
	Extended two VGA ports	LED-780HV2	1 VGA module includes 1 VGA input and 1 VGA loop
	Extended one VGA port and one SDI port	LED-780HVS	1 VGA module includes 1 VGA input and 1 VGA loop 1 SDI module includes 1 SDI input and 1 SDI loop
	Extended one SDI port	LED-780HS	1 SDI module includes 1 SDI input and 1 SDI loop
	Extended two SDI ports	LED-780HS2	1 SDI module includes 1 SDI input and 1 SDI loop
	Extended one DP port	LED-780HP	1 DP module includes 1 DP input

Port		Model	Explanation
Input port	Extended HDMI1.4 port one	LED-780HH14	1 HDMI module includes 1 HDMI(1.4) and 1 DVIinput(HDMI1.4 protocol)
	Extended dp1.1port one	LED-780HP11	1 DP module includes 1 DP(1.1) and 1 DVI input(DP1.1 protocol)
	Extended one USB port	LED-780HM	1 USB module includes one USB input
Output port	Extended monitor port one	LED-783H	One monitor port includes one IP real-time output and one DVI monitor output

Safety Instructions

- Please use the correct power supply according that the power input voltage for this product range is 100 ~ 240V AC, 50/60Hz.
- When you need connect or pull out any signal or bound guideline. Please confirm that all the power supply cords have been pulled out ahead.
- When you need to add hardware device for the LED video processor, make sure all of the signals and power cables have been pulled out ahead.
- Before you operate any hardware, please turn off the LED video processor's power, and to set you on the electrostatic by touching the ground surfaces.
- Please use the processor in clean, dry and ventilated environment, not use it in the high temperature, humidity environment.
- The product is the electronic product; please stay away from the fire, water and of which is inflammable and blast, dangerous.
- This product is with high pressure components, please don't open the case or maintain it by your own.
- As there is exceptional condition with smoke, ill-smelling, please turn off the switch at once and contact with the dealers.

Function Introduction

Brief

LED-780H, a superior approach to better visual performance for LED walls. It is a 4k*2k/60Hz capable video processor for 4 screens splicing. With EDID and user-defined output management, it delivers high quality pixel-to-pixel display via its user-friendly controls. It is an ideal choice for multi-media hall, multi-purpose room, theater, studio and showroom.

Supporting all kinds of input ports, it outperforms competitor products in terms of loading capacity and broadband utilizing rate (the up-processor width is 15360, and refresh rate reaches up to 120Hz). Also, 16 selective built-in resolutions allow user to scale and match the real size of LED walls.

Input ports include DVI*2, HDMI*2, DP*1 (4K), SDI*1 (with loop function). For extended inputs, user can choose 2 2K inputs (VGA, DVI, SDI, USB optional) or one 4K inputs (DP1.1, HDMI1.4 optional). It accepts network linking, USB linking or RS232 linking for different control demands.

About the front

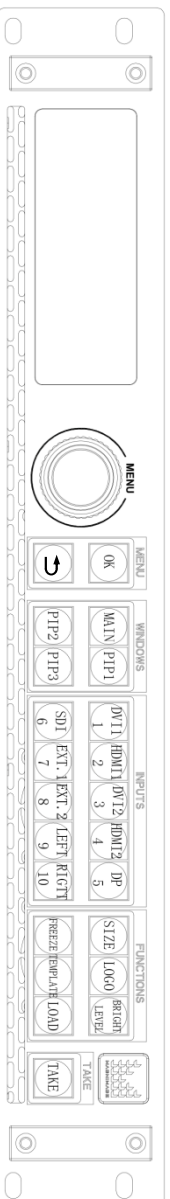

Button Introduction			
Knob	To move, select, or set the value	SDI/6	SDI input key/template 6
OK	To enter the main menu, or select the	EXT-1/7	Extended input key/template 7
↶	Return key	EXT-2/8	Extended input key/template 8
MAIN	Main image	LEFT/9	The left part of DP input/template 9
PIP1	PIP1	RIGHT/10	The right part of DP input/template 10
PIP2	PIP2	SIZE	Shortcut key to the size setting of image
PIP3	PIP3	LOGO	LOGO key
DV/1/1	DV/1 input key/template 1	BRIGHT LEVEL	To enter brightness level setting
HDMI1/2	HDMI1 input key/template 2	FREEZE	To freeze the output image
DV/2/3	DV/2 input key/template 3	TEMPLATE	Quick access to machine' s fixed templates
HDMI2/4	HDMI2 input key/template 4	LOAD	Quick access to presets
DP/5	DP input key/template 5	TAKE	Seamless switching on switching mode

About the back

LED-780H standard unit

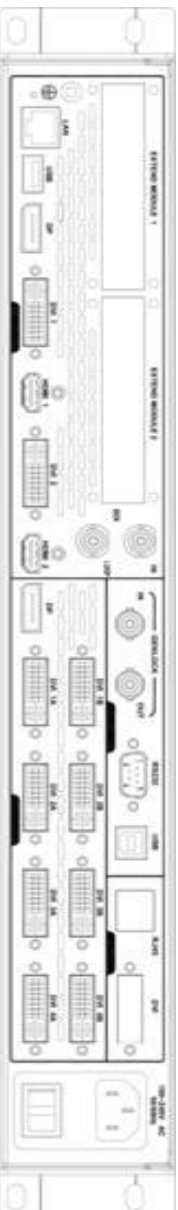

LED-780HDV: with 1 extended VGA input and 1 extended DVI input

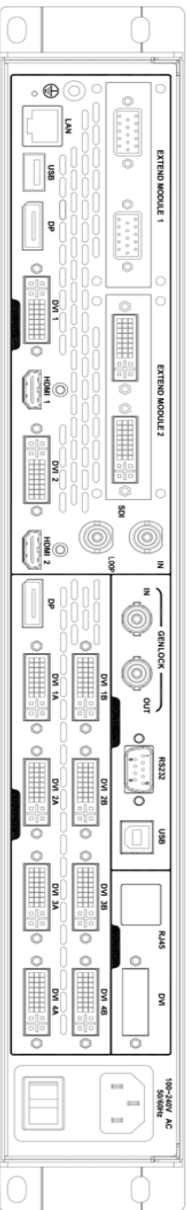

LED-780HP: with 1 extended DP input

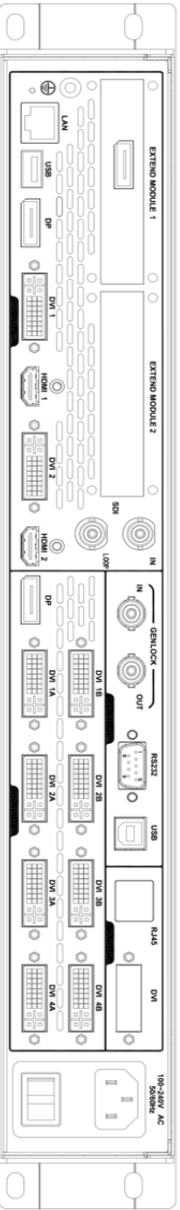

About the back

LED-783H: with extended DVI output to monitor and IP preview

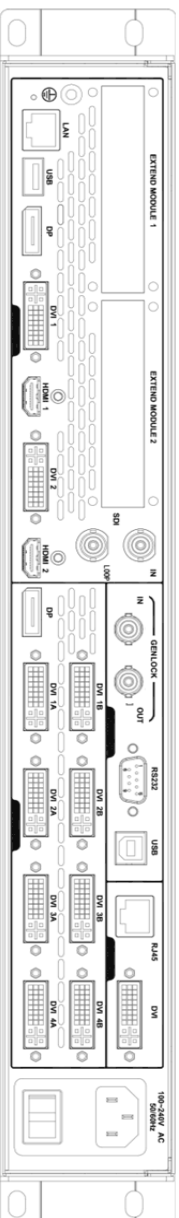

LED-780HS: with 1 extended SDI input

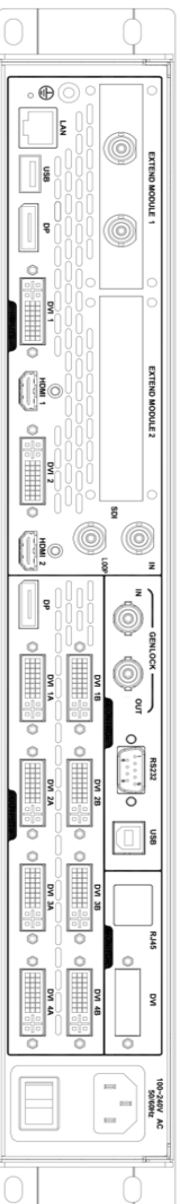

Input Port	
DVI1-DVI2	2 DVI input ports
HDMI1-HDMI2	2 HDMI input ports
DP	1 DP input port, 3840×1080/60Hz or 3840×2160/30Hz
SDI	1SDI input port, with 1 SDI loop
EXT.1	Extended port 1
EXT.2	Extended port 2

Output Port	
DVI1A-DVI1B	Output group 1, the DVI under is a backup port
DVI2A-DVI2B	Output group 2, the DVI under is a backup port
DVI3A-DVI3B	Output group 3, the DVI under is a backup port
DVI4A-DVI4B	Output group 4, the DVI under is a backup port
DP	DP loop for any input signal

Technical Specifications

Input Indication		
Port	Quantity	Resolution
DVI	2 available ports in a standard unit.	1024×768/60Hz、1920×1080/60Hz, or any other VESA standard resolution
HDMI	2 available ports in a standard unit.	EIA/CEA-861standard, HDMI-1.3
DP	1 available ports in a standard unit.	DisplayPort 1.1、1.2
SDI	1 available port in a standard unit.	480i/60Hz 、 576i/50Hz 、 720p/60Hz 、 1080i/50Hz、 1080i/60Hz、 1080p/60Hz (3G SDI)

Extended input indication		
Port	Quantity	Resolution
VGA	VGA×1、VGA LOOP×1	1024×768/60Hz、1280×1024/60Hz, satisfy the VESA standard
DVI	DVI×1、DVI LOOP×1	1024 × 768/60Hz、1920 × 1080/60Hz ,satisfy VESA standard
SDI	SDI×1、SDI LOOP×1	The same with SDI specification
DP	DP×1	Support 3840×1080×60Hz and customized
DP1.1	DP×1, DVI×1	DisplayPort 1.1, support 3840 × 1080 × 60Hz and customized
HDMI1.4	HDMI×1, DVI×1	HDMI1.4, support 3840 × 1080 × 60Hz and customized
USB	USB × 1(USB media module)	Support MP4/MKV/MOV/AVI/3GP video format, support BMP/JPG/PNG format picture, maximum video resolution supported 1920×1080/60Hz, maximum bitstream 80M

Extend 2K input for 2 port(DVI、VGA、SDI、USB optional), or 4K input for 1 port(DP 1.1、HDMI1.4)

Output Indication		
Port	Quantity	Resolution (each DVI output)
DVI	8 ports, 4 groups.	1024×768/60Hz 1280×1024/60Hz 1280×1024/59.94Hz 1024×768/120Hz 2048×1152/60Hz 1600×1200/60Hz-reduced 1920×1080/60Hz 1920×1080/59.94Hz 2176×1168/60Hz 1936×1280/60Hz 1536×1536/60Hz Customized output resolution (Bandwidth optimized): The width resolution is up to 3840 The height resolution is up to 3000
DP Loop	1	In accordance with DP input
SDI Loop	1	In accordance with SDI input

Whole Unit Specifications		
Input Power Supply	100-240V AC~50/60Hz 0.8A	
Working Temperature	0-45°C	
Overall Dimensions	482.6×452×66.75 mm (L × W × H)	
Net Weight	6.0KG	
Overall Power	55w	

Using Menu

Using the menu system is helpful to finish all your settings to this product. LED-780Hadopts a full color LCD screen to display the information. If there is no any operating or the operating is timeout, the LCD screen will be in default state. Pressing the knob and keys,the LCD screen will tell the correspondent information. Now let us start off the menu system.

How to use the keys

The front panel keys of LED-780H series products are divided into 5 areas: MENU、WINDOWS、INPUTS、FUNCTION and TAKE.

MENU:

There are 2 buttons, "OK" 、 " ➡" and one knob in this area.

Quick press to the knob is the same as pressing "OK" . When pressing, the system will return to the previous menu, until to the default status.

On the main menu, "OK" button is also used to switch from browse mode to setting mode.

Browse mode	Setting mode																
<table border="1"><tr><td>Picture Mode</td><td>Normal</td></tr><tr><td>Brightness</td><td>50</td></tr><tr><td>Contract</td><td>50</td></tr><tr><td>Color</td><td>50</td></tr></table>	Picture Mode	Normal	Brightness	50	Contract	50	Color	50	<table border="1"><tr><td>Picture Mode</td><td>Normal</td></tr><tr><td>Brightness</td><td>50</td></tr><tr><td>Contract</td><td>50</td></tr><tr><td>Color</td><td>50</td></tr></table>	Picture Mode	Normal	Brightness	50	Contract	50	Color	50
Picture Mode	Normal																
Brightness	50																
Contract	50																
Color	50																
Picture Mode	Normal																
Brightness	50																
Contract	50																
Color	50																
Press "OK" button or short press to the knob, we can switch from one mode to another.																	

In the browse mode, rotate the knob anticlockwise, the menu will go up or go left. Rotate the knob clockwise, the menu will go down or go right. Rotate and press the knob(or press "OK" button), the menu option will be selected. After that, rotate the knob anticlockwise, the value of the selected option will decrease, while the value will be increased when rotating the knob clockwise. For other menu's setting of this page, please swift to the browse mode. Press the return key to back to the previous menu. If the setting is finished, press return key until the default status, or stay for the operation timeout for auto return. At some menus like image switching window, preset window, and test pattern window, auto return will not occur when operation is timeout.

WINDOWS:

There are 4 buttons in this area, MIAN, PIP1, PIP2 and PIP3. They are in accordance with the selected image in the processor.

Long press to the button will turn on or turn off the selected image. White stands for used, and red stands for the current selected.

Quick press to the button will select the image.

INPUTS:

There are 10 buttons in this area, DVI1, DVI2, HDMI1, HDMI2, DP, SDI, EXT1, EXT2, LEFT and RIGHT. EXT1 and EXT2 are the extended ports. If the input is DP, the processor will internally cut the image into 2 parts, named LEFT and RIGHT.

Select the image at WINDOWS area, and the select the correspondent input signal.

Any button will turn white when there is input, and turn red if the input is selected.

FUNCTION:



There are 6 buttons in this area: SIZE、LOGO、BRIGHT LEVEL、FREEZE、TEMPLATE、LOAD.



Button	Default operating when pressing
SIZE	Enter the size setting menu
LOGO	Turn on or turn of the logo
BRIGHT LEVEL	Enter the brightness level menu
FREEZE	Freeze the current image
TEMPLATE	Enter the template window. These templates are available in this machine
LOAD	Enter the preset window. Preset is set by the user.

Default Status

After turn on the power supply, the machine will start the system, and then we can see the machine' s current status as below.

图 1 Default window when the machine is on

MAIN	DVI1	1920x1080	60Hz
PIP1	DVI1	1920x1080	60Hz
PIP2	DVI1	1920x1080	60Hz
PIP3	DVI1	1920x1080	60Hz
		1920x1080	60.00Hz
			

	Instruction
MAIN	The default image, its port type and input resolution.
PIP1	The port type and input resolution of PIP 1.
PIP2	The port type and input resolution of PIP 2.
PIP3	The port type and input resolution of PIP 3.
	The output resolution
	Mosaic function used
	Synchronize icon

Main Menu Introduction

Below symbols will appear in the main menu, their specific meaning are shown as below table:

Symbols	meaning
	Press "OK" to enter the submenu

Through "OK"、"↵" and the knob, setting the parameters or do some adjustment, below are the detailed introduction:

Purpose	Operation
Open main menu	By default, Press "OK"
Select	Rotate the knob to select the item
Parameter adjustment	Rotate the knob to change parameter
Enter the submenu	"▶" displayed in the right of the item, press "OK"
Performs	Press "OK" to confirm the item
Return to previous step	Press "↵"
confirmation	When do some operations, such as resetting, etc. To avoid the incorrect operation, need to use the "OK" key to confirm it.

Main Menu:

In the default state, press "knob" or "OK" to enter the main MENU state, the LCD screen will show the details as below:

Picture Setting	▷
Output Setting	▷
Mosaic Setting	OFF▷
Switcher Mode	OFF▷
PIP Settings	▷
Image Crop	▷
EDID Settings	▷
VGA Adjustment	▷
Communication	▷
Misc	▷
Sync Lock Setting	▷
Language/语言	▷
Keyboard Lock	▷
Language/语言	▷
User Guidance	▷

The main menu has twelve sub menu items, divided into three pages display. Rotating "knob" to select the above listed twelve sub menu title, selected, press "knob" or "OK" button to enter the selected project, press "↵" to be back.

Image setting submenu

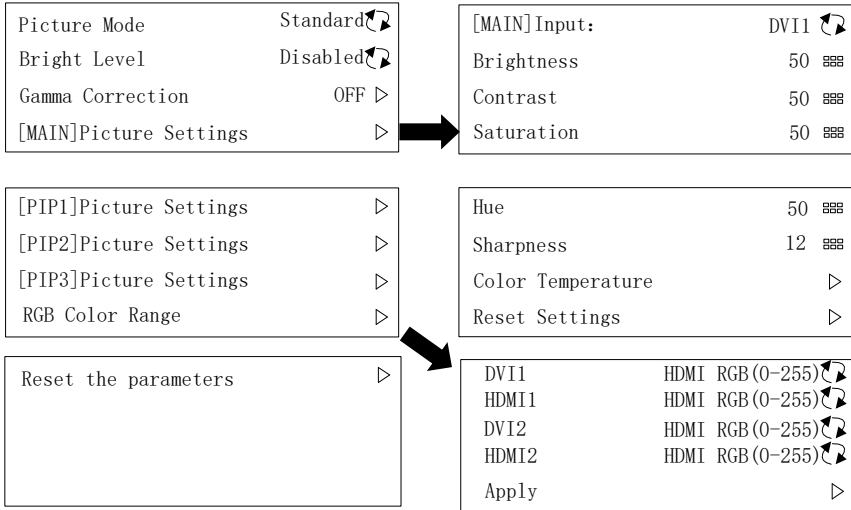

Image setting	Divided into "standard" 、 "low-light 1" 、 "low-light 2"、 "low-light 3"、 "video"、 "text"、 "monochrome"、 "user" ,totally 8 item.
Brightness level	Range0~16
Gamma correcting	Range 0~5
Brightness	Range0~100
Contrast	Range 0~100
saturability	Range 0~100
Hue	Range 0~100
Sharpness	Range 0~24
Color Temp	Divided into "user"、 "4000K"、 "5000K" 、 "6500K"、 "7500K"、 "8200K"、 "9300K"、 "1000K"、 "11500K" totally 9 options。
	red Range0~255
	Green Range0~255
	Blue Range0~255
Color range	HDMI RGB(0-255)and HDMI RGB(16-255)
Parameters restoration	Reset the parameters

Output setting submenu

Output Resolution ▷
 [MAIN]Output Window ▷
 [PIP1]Output Window ▷
 [PIP2]Output Window ▷



Select Output Resolution
 17 1024×1280 60Hz ▷
 18 1536×1536 60Hz ▷
 19 Customized Resolution ▷

[PIP3]Output Window ▷
 DVI Output Mode ▷



19th: Customized Resolution

H Active 1920 ⊞
 V Active 1080 ⊞
 FPS 60Hz ⊞
 Apply ▷



PIP3 ON 1920×1080
 Width 1920 Height 1080 ⊞
 H Start 0 V Start 0 ⊞
 Full Screen ▷



DVI1 DVI Mode ↻
 DVI2 DVI Mode ↻
 DVI3 DVI Mode ↻
 DVI4 DVI Mode ↻
 Apply ▷

PIP3 ON 1920×1080
 Roation OFF ↻
 Available in certain condition

Output Resolution	LED-780H support total 18 kinds of regular output resolution, and customized output resolution, horizontal maximum 3840, vertical maximum 3000. refresh rate maximum 121HZ, for details, check " output indicators ", 4 group individual output with same output resolution .
Output Window	H window Maximum is " the width of the current output resolution " . (for example:1024×768 60Hz, then it' s 1024)
	V window Maximum is " the height of the current output resolution " . (for example:1024×768 60Hz, then its 768)
	H Position Minimum 0 , the biggest can be set to the differentials between " the width of the current output resolution " and " H Window " ..
	V Position Minimum 0 , the biggest can be set to the differentials between " the height of the current output resolution " and " V Window "
DVI output mode	Adjust LED-780H 4 DVI output mode, default mode is DVI, and have HDMI mode(8 bit) and HDMI mode (10bit), solve problems of some device no accepting of processor output signal
Rotation setting	Include -90°、 90°、 horizontal、 vertical、 180°、 -90°+horizontal、 90° +horizontal totally 7 options

Please set the output resolution, H width and V height based on the physical resolution of LED screen. If do not have suitable output resolution, please select the options with bigger resolution than the reality. Or to choose the customize output resolution, to connect with the LED screen pixel to pixel directly.

For example, there is one screen 1152×960, the nearest option is "1280×1024 60Hz", in this condition, please set the output resolution as "1280×1024 60Hz" .besides,set the output H window same as the practical width of LED, namely "1152" ,so does the V window, "960" .also can use the customized output resolution, set the output resolution as "1152×960".

Note 1: LED-780H' s 4 groups output, their output resolution is same, while the output window can be set individually

Note 2: please be cautious when use therefresh rate that bigger than 60Hz or

use greater height and width pixel output resolution, it is not sure that the back-end equipment can support this resolution.

Note3: Customized output resolution is not the standard output signal, part of the monitor may not be able to identify, but does not affect the LED display, please use carefully.

Note 4: Output rotation only can be used in particular consideration.

Mosaic sub menu

Mosaic Setting OFF ↻

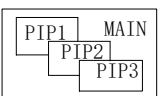

OFF
1 Panel 2 Panels
3 Panels 4 Panels



Mosaic Setting 4 Panels ↻

Manual Arrangement ▷

Auto Arrangement ▷

Manual Arrangement

Mosaic Setting MAIN ▷

PIP1 ▷

PIP2 ▷

PIP3 ▷



MAIN Mosaic Setting

H Total 1920 V Total 1080

Width 960 Height 540

H Start 0 V Start 0

Reset ▷

Auto Arrangement

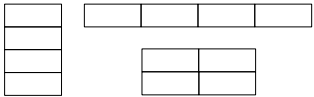

Press [OK] Confirm

Quick modaic

Direction H(From Left to Right) ↻

1st panel Width 1920 Height 1080

2nd panel Width 1920 Height 1080

3rd panel Width 1920 Height 1080

4th panel Width 1920 Height 1080

Left Scr DVI1 ↻ Right Scr DVI1 ↻

Calculate and apply ▷

In quick mosaic mode:

- 1、 Direction : Determined by the processor output mosaic arrangement, including horizontal, crossing and vertical splicing;
- 2、 Panel 1-4: Processor output DVI1-4 actual upload pixel
- 3、 Select the same input SCR for Left Scr and Right Scr if there is only one signal
- 4、 if the processor works with video server, for example two DVI source (or 4K DP), then select the Left source and Right source in this interface

Mosaic setting	To "open" or "close" the mosaic mode, default state is closed; include "close" , "1 panel " , "2 panels"、 "3 panels" , "4 panels " .
Manual Mosaic	For manual setting .
H total	The physical pixel points of the LED screen in horizontal direction
V total	The physical pixel points of the LED screen in vertical direction.
Width	The pixel points that the display area of the current video processor shown in the horizontal direction.
Height	The pixel points that the display area of the current video processor shown in the vertical direction.
H Start	The level starting position of the display area that controlled by the current video processor. The LED screen top-left corner is viewed as the original point (horizontal starting point 0).
V Start	The vertical starting position of the display area that controlled by the current video processor. The LED screen top-left corner is viewed as the original point (vertical starting point 0).
Auto arrangement	Calculate the mosaic parameter automatically to complete the mosaic.
Quick Mosaic	Set mosaic mode, pixel of each output, signal selection, to accomplish all the mosaic setting quickly

LED-780H series video processor mosaic setting , totally 6 mode:

Off: Close mosaic function, at this state, all the output ports output the same picture.

1 panel: All the output ports output the same picture, while system can capture the synchronous signal automatically, this model can use for cascading splicing.

2 panels 01: Output ports DVI1 & DVI2 splicing, DVI3 backup DVI1, DVI4 backup DVI2. MAIN and PIP1 are used on DVI1/3 and DVI2/4.(commonly used)

2 panels 02: Output ports DVI1 & DVI2 splicing, DVI3 backup DVI1, DVI4 backup DVI2. MAIN and PIP2 are used on DVI1/3 and DVI2/4.

3 panels: Output ports DVI1, DVI2 & DVI3 splicing.

4 panels: Output ports DVI1, DVI2, DVI3&DVI4 splicing.

Switcher mode sub menu

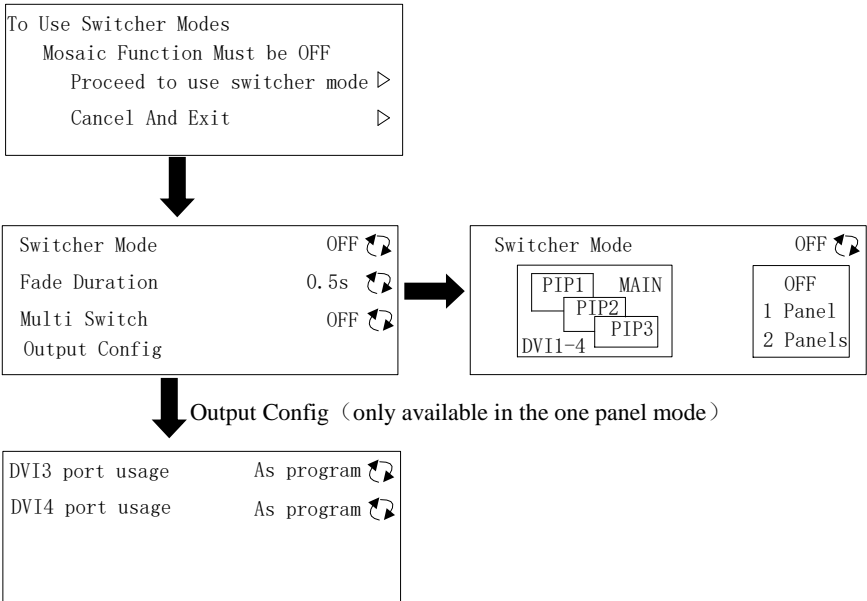

Switcher mode	include "OFF ", "single screen "and "dual screen "
Fade duration	Range 0-3 second
Multi switch	Through the "TAKE" key, to realizesynchronous switching for multi 780H within same area network
Output Config	Set the DVI3 and DVI4 output as normal PGM output or individual output (only available in one panel output)

Switcher mode do not work together with mosaic mode

LED-780H series switcher mode, totally 2 options:

Off : Turn off the the switcher mode function

1 panel: output DVI1 output preview, there' s a "Preview" in red displayed in the top left corner, DVI2、 DVI3、 DVI4 is the program output, output the same image.

2 panels: output DVI1、 DVI2 output preview, there' s a "Preview" in red

displayed in the top left corner, DVI3、 DVI4 is the program output .

By the " TAKE" key in the front panel, realize fade switching between preview & program.

By using TAKE button in the processor front panel to proceed preview and program fade in and fade out switch.

PIP Setting

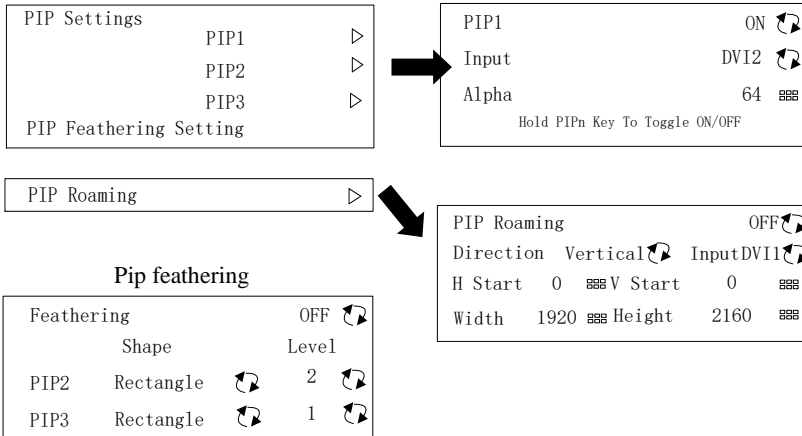

In pip setting sub menu, do such adjustments :open PIP or turn off PIP, and select input signal ,transparency adjustment (0-64)

To change the PIP size, use the “SIZE” key in the front panel .

PIP feathering: Only available in processor Mosaic Mode-Two panels, to make feathering for the fringe of the windows. Shape can be selected: Rectangle, Rectangle Left, Rectangle Right, Rectangle Up, Rectangle Down, Level can be selected 1,2,3

PIP roaming: Only available in processor Mosaic Mode-Two panels, After this mode opened, the second picture size and position and input source can be determined with the parameters.

Image crop setting sub menu

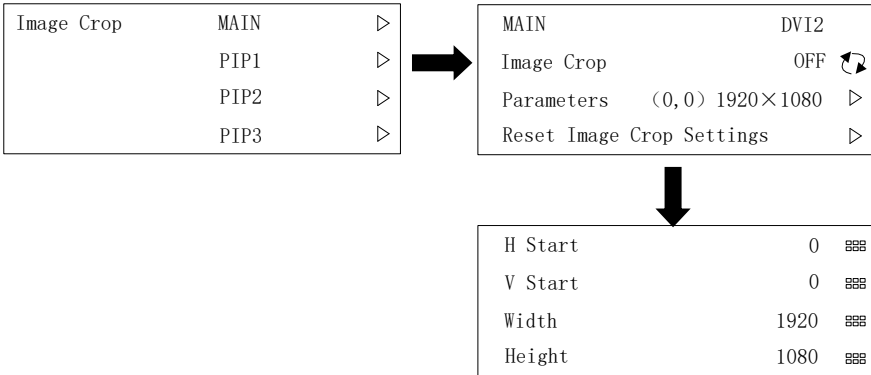

Image crop	select "MAIN"、"PIP1"、"PIP2"、"PIP3" cropping parameters; each signal can be cropped in different picture at the same time.
Image crop Parameters restoration	Restore the MAIN,PIP1,PIP2,PIP3 cropping parameters
Horizontal	Maximum is "width of input signal"
Vertical	Maximum is " height of input signal "
H Position	Maximum can be set to the differentials between "the width of the current output resolution" and "H Window" .
V start	Minimum 0, the biggest can be set to the differentials between "the height of the current output resolution" and "V Window"

Image crop function is cropping the input signal, and output to LED screen according to setting of windows. So the size and position of image crop window is limited in the window of input signal. Setting parameter in above chart are restricted.

EDID setting

EDID Select	DVI1	
H Active	1280	
V Active		
FPS	60Hz	
Apply		

Advanced	
Restore	

Edid Advanced Setting	
H Blank	
V Blank	
Apply	

EDID select	select one input signal EDID
-------------	------------------------------

H Active	Horizontal width
----------	------------------

V Active	Vertical height
----------	-----------------

FPS	Refresh rate
-----	--------------

After setting EDID, different PC, different video card, need restart PC or pull ot signal line, choose appropriate resolution in PC resolution output menu.

VGA adjustment

VGA Position Adjustment	▷
VGA ADC Adjustment	▷
VGA DDC Setting	▷

VGA Position Adjustment			
Input	VGA1 ↻	Auto Adjust	▷
Clock	1792 ↻	Phase	20 ↻
H Position	0 ↻	V Position	0 ↻

VGA position adjustment	Adjust VGA signal position and time clock manually or automatically
VGA ADC adjustment	Adjust VGA color adjustment after upgrading, need work with adjustment card
VGA DDC settings	

Communication Setting

Network Settings	▷
RS232 Baudrate	115200



IP:	192.168.1.110 🌐
Apply	▷
Reset	▷
MAC:	E2-CB-16-E0-73-6F

Network settings	Select IP address of this PC
RS232 Baudrate	Fixed value 115200

Misc Setting

Display in two pages

LOGO Settings	▷
Chroma Keyer Settings	▷
Templates And Presets	▷
Time/Task Managment	▷

Loop Out Settings	DVI1	
Pattern/Caption		▷
Output Monitor		▷
Input Signal Backup		▷

Input Select Method	Freeze	
System Information		▷
Factory Reset		▷

LOGO Setting

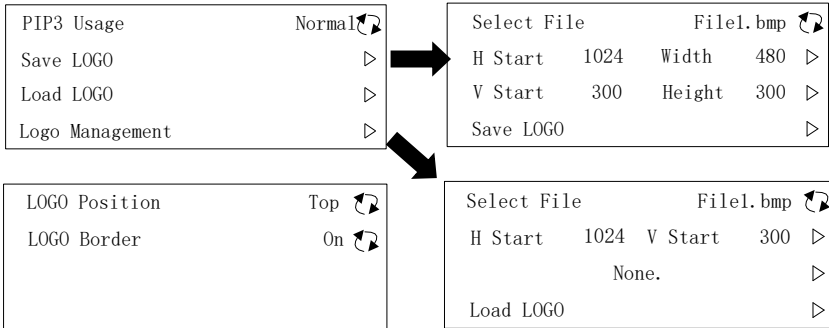

PIP3 function	Modify normal state, used as activity picture. Modify logo state, used as LOGO function; PIP3 and LOGO occupy same output, can choose one of both.
Save LOGO	Modify store file, maximum 4 Save PIP3 picture as LOGO, adjust size and position in save interface Horizontal area: maximum value is the width of PIP3 Vertical area: maximum value is the height of PIP3 H start: maximum value is the difference of PIP3 height and LOGO width V start: maximum value is the difference of PIP3 height and LOGO width
Load LOGO	Select one LOGO file, one per time H stat: horizontal position of LOGO V star: vertical position of LOGO After loading, on or off LOGO via LOGO button in front panel
LOGO management	Can clear all save LOGO file
LOGO position	Can select top or bottom, default state is top
LOGO border	In the process of saving and loading LOGO, display a frame in output display screen to remind the position and size of LOGO

Note : PIP3 and LOGO occupy same output, can choose one of both.

Chroma keyer settings

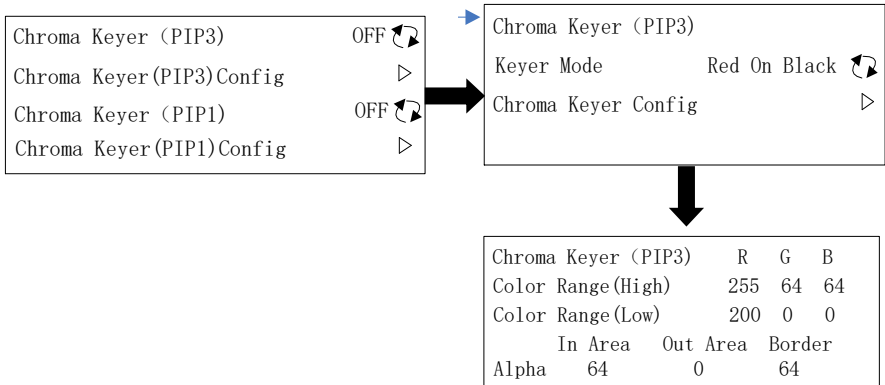

Chroma keyer	On or off chromakeyer function
keyer mode	User, white on black, white on black 2, black on white, black on white 2, green on black, green on black 2, green on white, green on white 2, red on black, red on black 2, red on white, red on white 2
Color range	Adjust red green blue separately, range from 0 to 255

※: One panel and Two Panel01, Three panels Chroma keyer function only work in PIP3

Two panel Mosaic02 mode Chroma keyer function work in PIP1 and PIP3

Templates and Presets

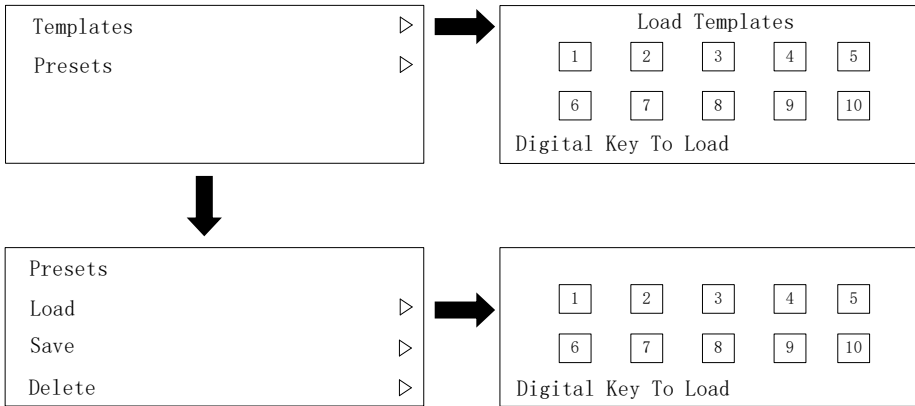

template	Load fixed template; enter adjust interface via template button in front panel
Presets	Load: in loading interface, load presets via pressing No. button, also enter load interface via LOAD button in front panel. Save: enter save interface, save presets via pressing No. button.
Delete	Enter delete interface, delete presets via pressing No. button

Time & Task management

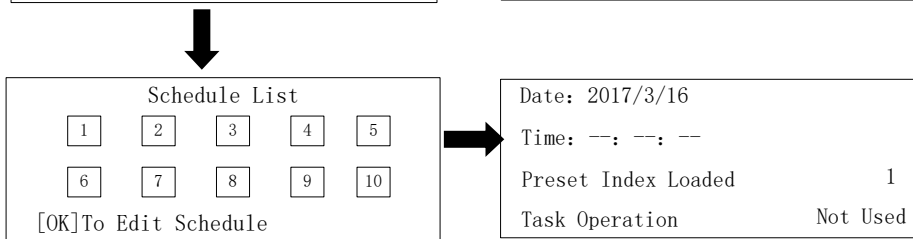
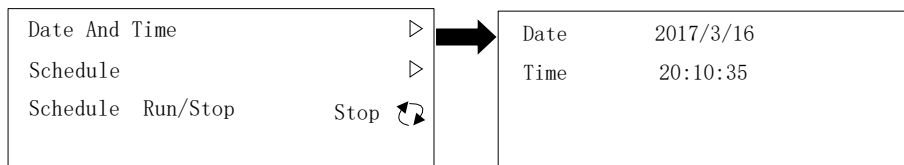

Data and time	date	Set date
	time	Set time
Schedule	Date	Set date
	Time	Set time
	Presets index	Load appropriate presets index
	Task operation	Included "not use" 、 "once" 、 "every day"
Schedule run/stop	Select schedule run or stop	

Pattern/caption

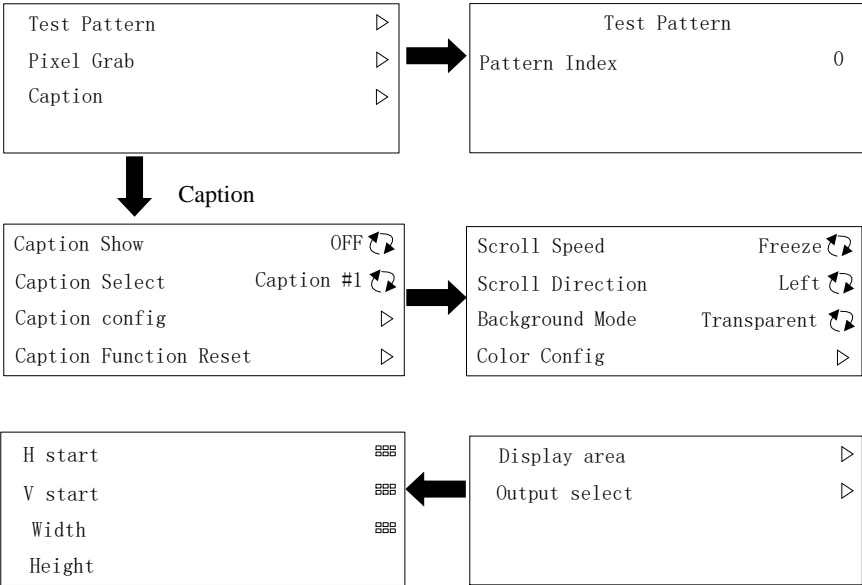

Test pattern	Range 0-110 ; 0 represent no test pattern display, 1~72 test pattern No.。
Pixel grab	Modify horizontal and vertical position, show current color
Caption	Scroll speed included "freeze"、"speed 1"、"speed 2"、"speed 3"。
	Scroll direction included "left "、"right"
	Background mode Set caption transparency, included "translucent"。
	Color config Set caption color, support user

Caption words input, need work with LED-780H software, and the maximum width of caption is 3840.

Output monitoring

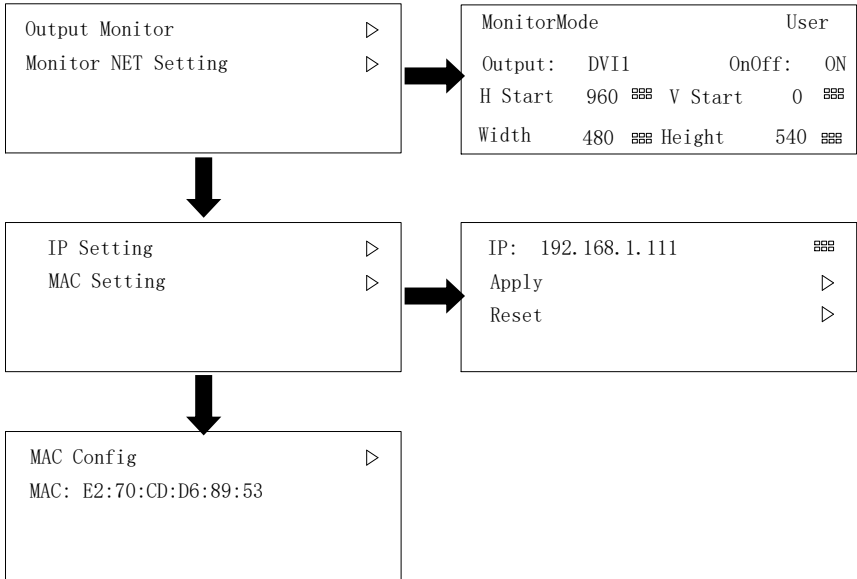

Input signal backup

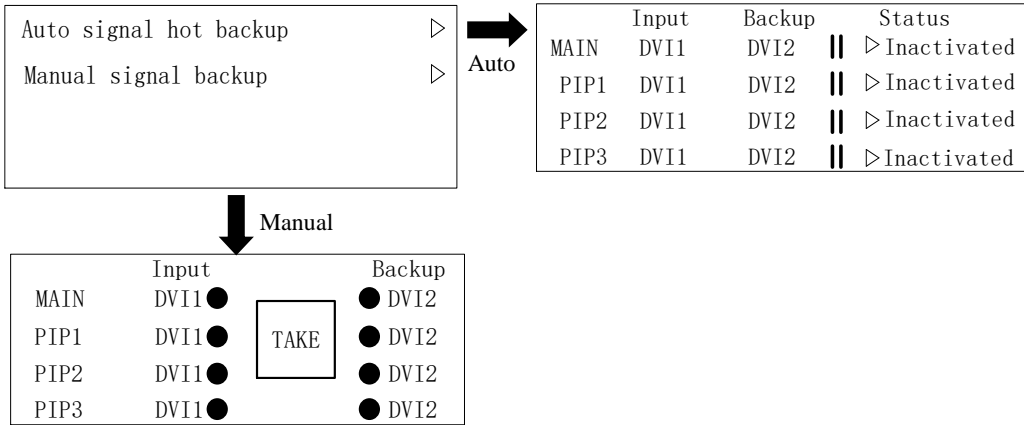

Auto signal backup	Select corresponding layer, then select current input and backup input signal, finally select task bar, make backup activated. For example: main picture is input DVI1, Backup is input DVI2, when current signal lost , output picture will switch automatically to DVI2
Manual signal backup	Select corresponding layer, and then select current input signal and backup signal, by using "TAKE" button to achieve backup signal switched to current output layer

Input Select Method

The output image switching effect when users change the input source, default setting is Freeze, the other effect is black screen. i.e. keeping freeze frame to switching from one signal to another or black

System information: Check processor current system version

Factory reset: To do factory reset for the processor

Synchronization Lock Setting

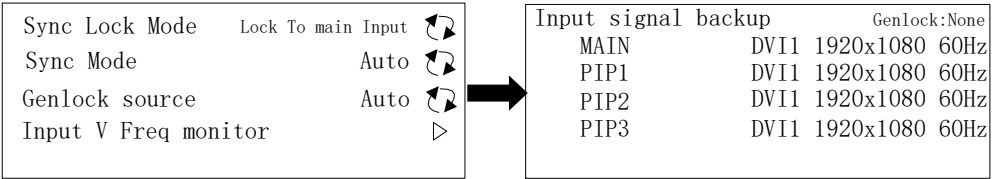

Synchronization Lock Mode	Include "synchronize to Main"、"synchronize to Genlock"、"synchronize to input DVI1"、"synchronize to DVI2"、"synchronize to HDMI1"、"synchronize to HDMI2"、"synchronize to DP"、"free-rolling" .
Synchronization Mode	Include "automatic"、"Mode 1 "、" Mode 2"。

- 1、 Single Machine Splicing: the Parameters of Synchronization lock setting are used default setting;
- 2、 Multiple machine horizontal mosaic, Synchronize lock mode: set as corresponding input signal;
Synchronous mode: automatic
- 3、 Multiple machine vertical mosaic, Synchronize lock mode: set as corresponding input signal;
Use of synchronous mode: automatic, in case it asynchronous, try mode 1 or mode 2 advisably, they are different delay processing mode.
- 4、 Enter the refresh rate information: you can view the specific input refresh rate (accurate to 0.01), if the screen splicing is not synchronized (synchronization icon does not appear), check the menu shows the input refresh rate; then the processor output Refresh rate into line with the input refresh rate can be

Extend input port

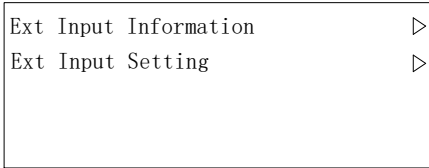

Under this menu, you can view the information of the input expansion port and set the port switching rule.

Keypad Lock

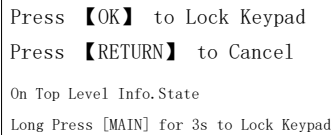

Press **【OK】** to Lock Keypad
Press **【RETURN】** to Cancel
On Top Level Info.State
Long Press [MAIN] for 3s to Lock Keypad

This menu can lock the processor's keys, you need to press any key to unlock, prompt button 1276 to unlock.

Language/语言 Submenu

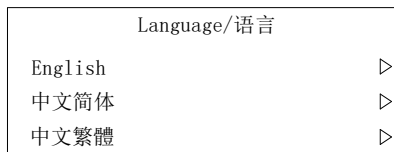

English	System language show as English
Simplified Chinese	System language show as Simplified Chinese
Traditional Chinese	System language show as Traditional Chinese

User Guidance

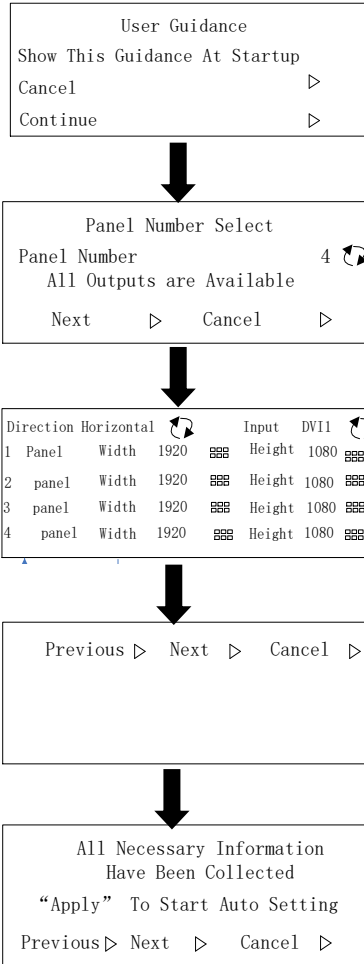

Based on the setting guidance to make the screen quickly, more parameters adjustment please set them correspondingly on the menu.

Mosaic function

basic setting steps of LED-780H video processor:

1. adjust output resolution (means the individual output resolution)
2. on mosaic setting: select a mosaic mode (can be chosen according to number of outputs used).
3. On mosaic setting---select Quick Mosaic





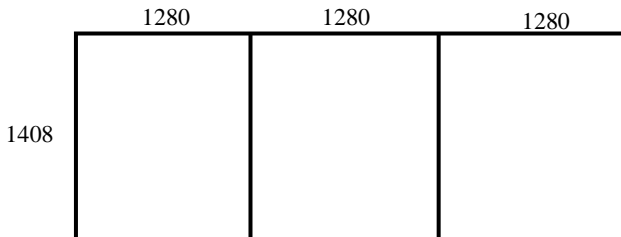



Single input scaled-up mosaic

For Example: P3.91 LED Screen, 15m x 5.5m, total resolution is 3840 x 1408, divided into 3 load area, like below:



Quick splicing method:

- 1, Output setting select output resolution, the 19th customized resolution set 1280x1408x60Hz
- 2, Select three panels mosaic in mosaic setting
- 3, Select Quick Mosaic(three panels) in mosaic setting

Direction				Horizontal	
Left Panel	Width	1280		Height	1408 
Middle Panel	Width	1280		Height	1408 
Right Panel	Width	1152		Height	1408 
Left Scr	DVI1			Right Scr	DVI1 

Calculate and apply ▶

Only for same LED cases

Multiple input scaled-up mosaic

Considering display definition, sometimes it requires video server output 2 DVI or 4K DP signal to video processor to archive clear images, meantime, there is a little different from single input scaled-up mosaic.

2 DVI input horizontal scaled-up mosaic

Single machine 2-panel mosaic

Video server output 2 DVI signal (1920x1080) to LED-780H synchronously, LED-780H output for 3 panels mosaic;

For example: P4.81 LED screen, 23m x 5m, total resolution is 4784x1040; divided into 3 load area, as below:

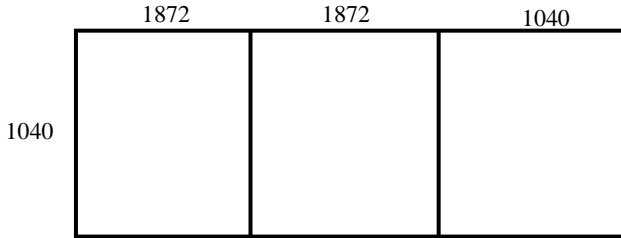

Input 2 DVI, both 1920x1080

Quick mosaic method:

- 1, Output setting select output resolution, the 19th customized resolution set 1872x1040x60Hz
- 2, Select three panels mosaic in mosaic setting
- 3, Select Quick Mosaic(three panels) in mosaic setting

Direction				Horizontal	
Left Panel	Width	1872		Height	1040
Middle Panel	Width	1872		Height	1040
Right Panel	Width	1040		Height	1040
Left Scr	DVI1			Right Scr	DVI2

Calculate and apply

Only for same LED cases

NOTE of DP

Regarding LED-780H DP input, in 2K resolution situation, press DP button to select current DP input; in 4K resolution situation, DP input will be split into DP-L and DP-R automatically, L presents left part of 4K input and R presents right part;

So 1 completed 4K signal includes DP-L and DP-R;

Two DVI input scaled-up mosaic as mentioned above, can also be replaced by DP-L and DP-R

Controlling Software operation introduction

LED-780H controlling software(called the software) is professional software aimed at video processor. The interface is Intuitive concise, easily handle, and almost all the function of controller can be realized by the software. Working with “output preview board” , we can check the real-time input signal in the interface of the software.

Running Environment

- CPUfrequency \geq 1.6GHz
- RAM \geq 1G
- Video memory \geq 512M
- Windows XP \ Windows 7 (32 Bit or 64 Bite) \ Windows 8 (32 Bit or 64 Bite)
- Minimum Display Resolution: 1024 \times 768

Install and unload

Read the disc with the equipment, and find “MIG_780-SetupVX. msi” , double click it, it requires restart the PC to finish the installation if it not existed before, or it will start to repair or uninstall the software.

Installing processing

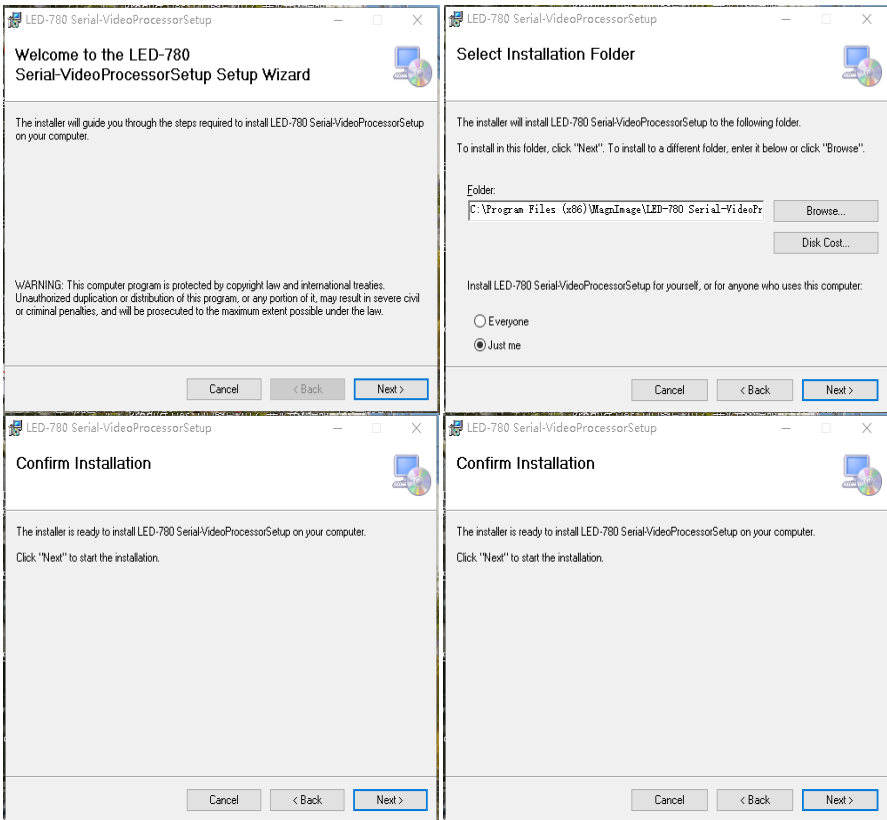

- Double-click program start install,click "Next" to go on.
- Select program installation location, and setup the program user.
- Confirm all the setting, and click "Next" to go on.
- Ask for uses-permission, please select "Yes" .
- When they finish, please click the "Close" . And you got it.

Unload the software

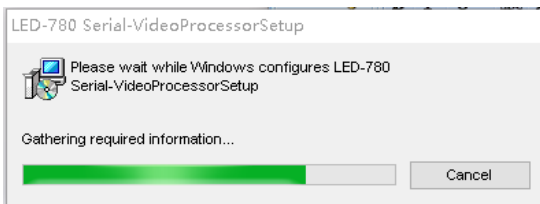

- Double-click the installer, start the uninstalling with the software, click "Next" to go on.
- Finish and click "Close" .

Open the software

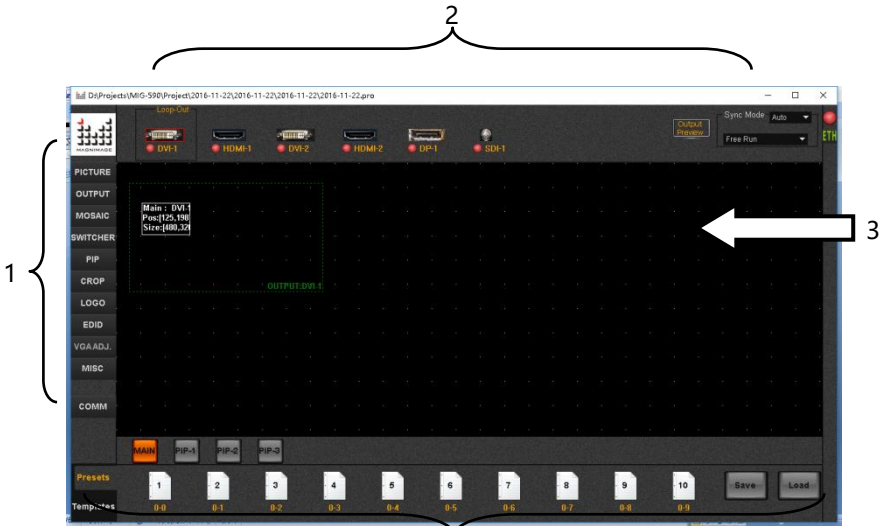

After opened the software, you will see ⁴ parts in your PC.

- 1、 Functional area
- 2、 Signal selection area
- 3、 Operation area (black area)
- 4、 Area templates and presets.

Connection setting

Connection Settings: network connection and COM connection

1, Network connection

a> Destination IP: IP Processor

b>Local IP: Computer IP address

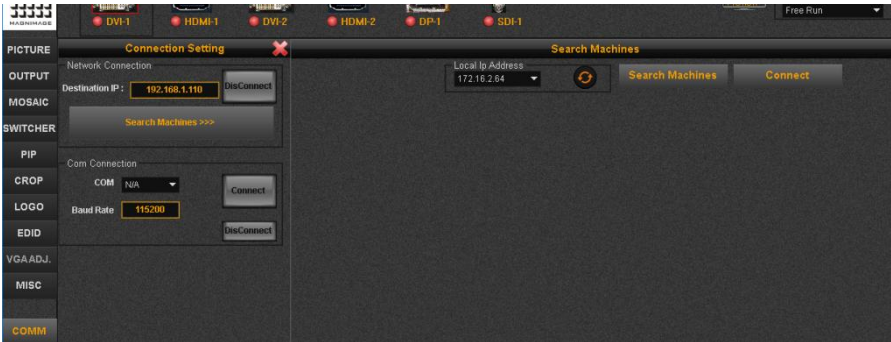

Destination IP and the local IP in the same network, click "search" machines, will open a list, select "connect". If succeed will be reminded, the diagram below:

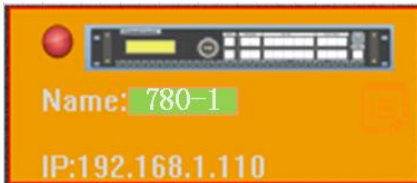

Double-click the icon, select the machine

2, COM connection

Connect via RS232 serial port, Baud rate is 115200

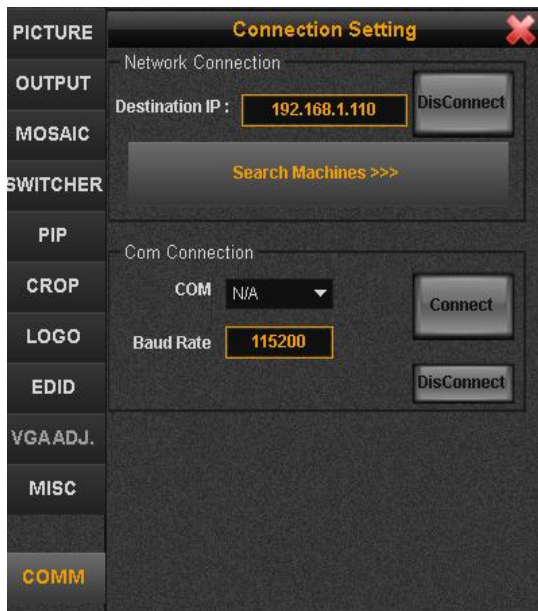
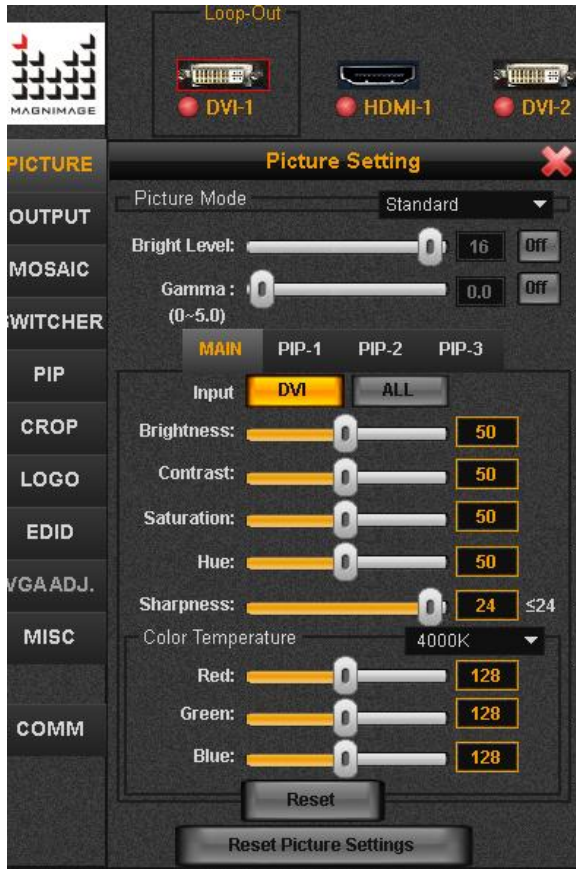

Image setting



Picture mode	Standard, Low light, Monochrome, Video, Graphic, User
Layer	Choose MAIN/ PIP1/2/3, change what you want
Temperature	Change the color temperature, RED/ GREEN/ BLUE.

Open Picture Mode to User at first, and that you can change Layer and Temperature.

OutputSetting



Output Resolution	Choose a fixed output resolution and customize output resolution
Output window	Select pictures, change the size and position of the corresponding picture
Rotation	rotation angle of the output image

Mosaic Setting

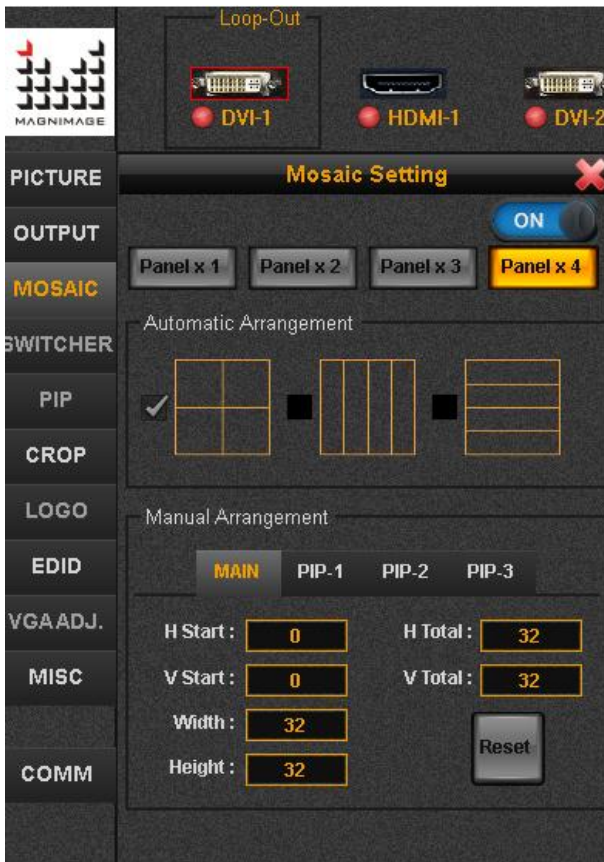

Mosaic mode	Mode: Panel*1, Panel*2, Panel*3, Panel*4. Corresponding is Single output, two screen, three screen, four screen mosaic. And turn on/off the Mosaic mode.
Automatic Arrangement	Choose the splicing position, such as horizontal, vertical, grid-shaped.
Manual Arrangement	Change each splicing output resolution, to realize image stitching

Switcher Mode



Switcher Mode	Mode: Panel*1, Panel*2 Panel*1: One is preview, and one is program. Panel*2: Two is preview, and two is program.
Fade duration:	Change fade time
Multi-Machine Mode:	One computer control multiple machines , switch at the same time

PIP



PIP1	PIP 1 turn on/off, select input signal and change the alpha.
PIP2	PIP 2 turn on/off, select input signal and change the alpha.
PIP3	PIP 3 turn on/off, select input signal and change the alpha.
T-BAR	Fade in/out on this screen

Image Crop



Yellow area: the size of the input signal

Black frame: the size and position of the video crop

"Video Crop" is realized by cropping the input signal, transferring to the LED display according to the size of output port and then presenting the image. Thus the size and position of the video crop is based on the set up of the input signal. Every parameter mentioned influences each other.

LOGO Setting



PIP3 Mode	LOGO is only applied in the PIP-3, please enter the logo mode in PIP3 for the need of LOGO
Position	Adjust the size and position of the LOGO
File	LOGO file loading and clear
LOGO Setting	LOGO top or bottom
LOGO Border	Used in the grab or load time, Prompt LOGO location and size

EDID Setting



Select an input source, and then change the width, height, frame rate, adjust to the corresponding input resolution; Then click Apply,

Front-end settings will automatically recommend this resolution output to the processor, if it does not appear, please reboot the front end setting (for example, restart the computer) or re-insert the input signal line

VGA Adjustment



Display Adjustment	In the case of position offset, apply VGA correction, generally choose“ Auto Adjustment”
ADC Adjustment	Adjust the color of the VGA signal
DDC Setting	DDC setting is only for on/off switch, please contact our technician for the other two settings.

Misc Setting



Language/语言 Select English or Chinese interface

File Location Save and load project files

Loopout Setting DP loop port allow options of loopout of any signals

System Information System software version, firmware information

Factory Reset To reset the machine to the factory setting



Color Key It is efficient only PIP-3

Color Key Mode You can choose shortcut mode or user-defined mode. For example, white-on-black writing, which means it will remove the black bottom automatically, only leave white text. Then, it will have the effect of words superposition.

Pattern/Caption



Test	Pattern	The processor outputs the local test signal
Read	Pixel	By adjusting the position, read the current pixel color
Subtitle Setting		Enter the advanced setting of subtitle, Just edit subtitle info in the software, including subtitle content, font size, color, location; Scroll speed, direction, background color and other information,after editing is completed,Click "preview" Sent to the processor

Time & Task



Time	Time on the machine can be synchronized with time on computer
Schedule	The Switch of Schedule, a total of 10 time tasks, can be edited separately

Task Editor	Select a trigger time, and then select a trigger cycle, finally select the trigger action, Such as call the default time at 12:00 every day 2, Time is set to 12:00,Task Action Select "Daily" Then click Apply For example, apply preset 2 at 12:00 everyday, set the trigger time to be 12:00;trigger action to be " Daily" Preset selection "2",Then click Apply
-------------	---

Input Source Information



Input Source Information	Green light on and resolution display with signal input, otherwise the red light on Loop Out shows the signal source at DP loop port ;
--------------------------	---

Synchronous Mode



Synchronous Mode	The machine provides multiple synchronous modes, or is directly synchronized to an input source. Generally use the default settings.
------------------	--

Preset and Template

Below the software interface, preset and template options are available

1、Preset



Save	After setting up all the items, parameters can be saved,10 items in total
------	---

Load	Load the saved parameters
------	---------------------------

2、Templates



Templates	For the convenience of customer, 10 fixed patterns in total are installed in factory setting.
-----------	---

Warranty

The whole unit warranty

- Two years (from the buying date);
- If the invoice is lost, the 60 days after the production date will be the warranty start date for the product.

The warranty provisions

- The machine soaking and collisions produced by surface scratches and other abnormal using causes of malfunction or damage;
- Demolition machine or modification, which is not to be agreed by our company;
- Using in the not specified used working conditions, resulting in fault or damage (such as high temperature, low voltage or unstable etc.);
- Force majeure (such as fire, earthquake, etc.) or natural disasters (like lightning, etc) caused the fault or damage;
- Beyond the product warranty.